



Ride-By-Wire connection

^ Table of contents

▸ Introduction

▸ Installation and configuration

▸ Ride-by-Wire connections

Introduction

This user manual is an integral part of the dynoKRAFT ADAQexiom controller hardware.

©2024 dynoKRAFT GmbH, all rights reserved.

This manual is copyrighted by dynoKRAFT GmbH, hereafter referred to as dynoKRAFT, all rights are reserved. This product and all its components are a custom built device designed for professional use, and to be used solely at research and development facilities for such purposes.

Original User Manual for Ride-By-Wire controls in combination with dynoKRAFT ADAQexiom hardware. This manual the controller and/or software described in it, is furnished under license and may only be used in accordance with the terms of such license.

This manual is furnished for informational use only, is subject to change without notice, and should not be construed as a commitment by dynoKRAFT.

dynoKRAFT assumes no responsibility or liability for any error or inaccuracies that may appear in this manual. No part of this manual may be reproduced, stored in a retrieval system, or transmitted, in any form or by any means, electronic, mechanical, recording, or otherwise, without the prior written permission of dynoKRAFT. Any trademarks, trade names, service marks, or service names owned or registered by any other company and used in this guide are the property of their respective companies.

Manufacturer / Service / Warranty:

dynoKRAFT GmbH
Hugo-Eckener-Str. 33
D-50829 Köln
Germany
info@dynokraft.de

Installation and configuration

Ride-by-Wire connections

NOTE

The Ride-by-Wire connection override the vehicles built-in throttle input. In most cases connecting external Ride-by-Wire emulator to vehicles wiring system will trigger fault codes.

This connection should be performed only by experienced vehicle electrician that understands how ride-by-wire systems works.

Overview of Ride-by-Wire connections

ADAQexiom

Ride-by-Wire connections

Throttle signal to ECU - THR1

Pin 7: GND (ground)
Pin 8: THR1 (throttle 1)

Throttle signal to ECU - THR2

Pin 7: GND (ground)
Pin 8: THR2 (throttle 1)

24V DC Power supply
to signal converters
Pin 1: V-
Pin 2: V+

Converter input 4, 5

Connect the signal from O1, O2, GND
to input Pin 4 and Pin 5

Converter THR1
Pin 4: GN (ground)
Pin 5: O1 (throttle 1)

Converter THR2
Pin 4: GN (ground)
Pin 5: O1 (throttle 1)

ADAQexiom output O1, O2
Signal type: 5V PWM, 0-100% Throttle
Trim the output using ADAQexiom
plugin Configuration

O1- output 1 - usually THR1
O2 - output 2 - usually THR2
GN - ground

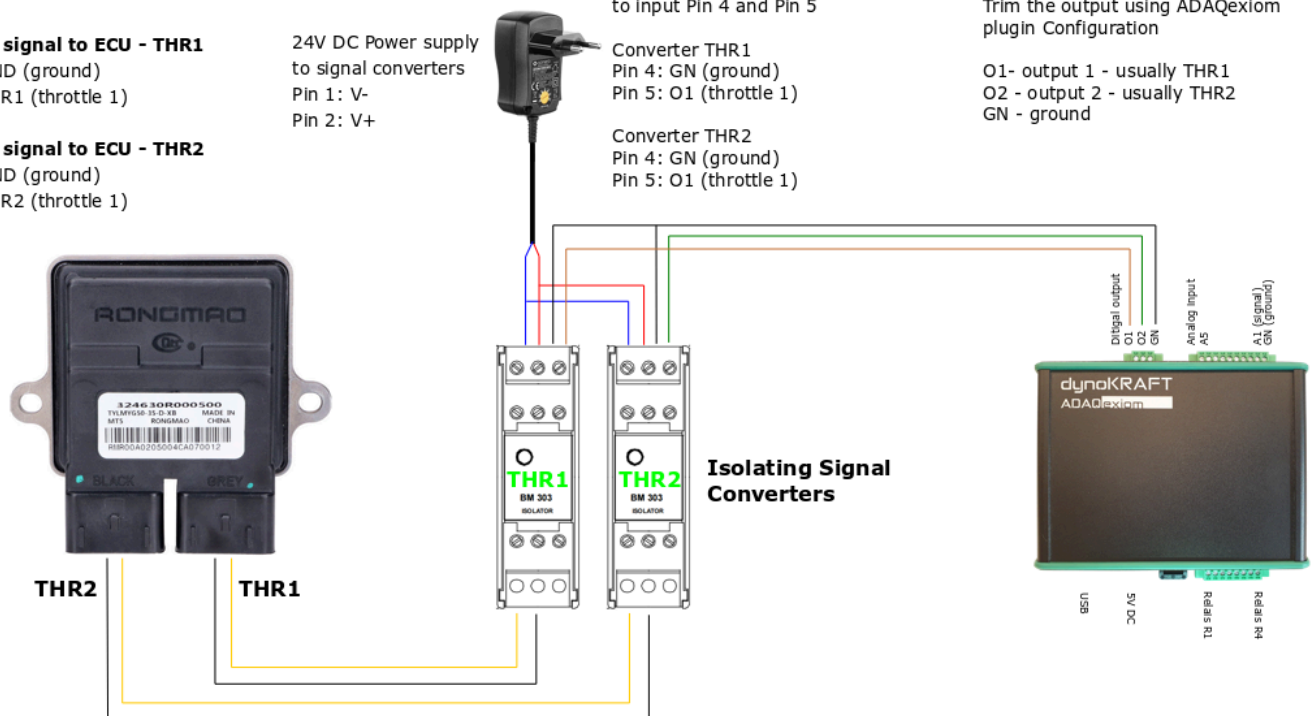

Step-by-step instructions

1. Please connect the ADAQexiom digital output O1 and O2 to signal converters 1 and 2 respectively.

2. Signal converters themselves are to be connected to 24V DC Power Supply. Please refer to attached BM303 User Manual PDF at the bottom of this page.

3. The output scaling can be adjusted using the two screw-potentiometers hidden behind the front cover of the signal converters. Please see manual for details on the adjustment procedure.

The default scaling is INPUT = OUTPUT 0-10V DC

4. Connect the Output from Signal Converter directly to vehicles ECU.

⚠ **CAUTION. Possible damage to vehicle electric system**

When connecting the Signal Converter output to vehicle ECU make sure to disconnect the battery and turn ignition OFF first.

5. Adjust the ADAQexiom Output Trim in "ADAQexiom Plugin Configuration".

See wiki article: https://support.dynokraft.de/portal/en/kb/articles/adaqexiom-user-manual#THR_Controller_ID1