



Dynamometer Service Manual

^ Table of contents

- ▲ Introduction
- ▲ Warranty and Disclaimer
- ▲ Conventions used in this manual
- ▲ Precautions and dynamometer safety
- ▲ General Information and Maintenance Schedule
 - ▲ General advice
 - ▲ Bolt Torque Chart per DIN 267
 - ▲ Maintenance schedule
- ▲ Service Procedure
 - ▲ 1. Mechanical System
 - 1.1 Check for loose components or visible damage.
 - 1.2 Re-grease all bearings
 - 1.3 Check Main Bolts
 - 1.4 Check / Change oil in Link Gearbox
 - 1.5 Check and re-grease Link Shaft
 - 1.6 Check Spindle Drive system
 - ▲ 2. Electrical system
 - 2.1 Function check
 - ▲ 3. Pneumatic system
 - 3.1 Air pressure
 - 3.2 Pneumatic E-stop brake(s)
 - 3.3 "Air" indicator function check

- 3.4 Drain water from air bottle
- ▲ 4. Software and ADAQ check
- ▲ Final Notes

Introduction

This service manual is an essential part of the dynoKRAFT dynamometers, intended to be used only by experienced technicians performing servicing of this product.

© 2026 dynoKRAFT GmbH , All rights reserved.

This manual is copyrighted by dynoKRAFT GmbH, hereinafter referred to as dynoKRAFT. All rights reserved. Original installation manual for the dynoKRAFT dynamometer.

This manual is for informational purposes only, is subject to change without notice and should not be construed as a commitment by dynoKRAFT.

dynoKRAFT GmbH assumes no responsibility or liability for errors or inaccuracies that may appear in this manual.

No part of this manual may be reproduced, stored in a retrieval system, or transmitted in any form or by any means, electronic, mechanical, recording or otherwise, without the prior written consent of dynoKRAFT.

All trademarks, trade names, service marks, or service names owned or registered by another company and used in this manual are the property of their respective companies.

Manufacturer / Service / Warranty:

dynoKRAFT GmbH

Kolonnenstr. 8

D-10827 Berlin

Germany

info@dynokraft.de

Warranty and Disclaimer

⚠ This products is meant to be serviced by trained technicians only.

i All dynoKRAFT Service Manuals are available only in English.

Not all described procedures are applicable to all dynamometer models. If in doubt please contact dynoKRAFT Technical Support.

The service technician assumes responsibility for his or her own actions when servicing dynoKRAFT products. dynoKRAFT GmbH hereby expressly disclaims liability and shall not be responsible for incidental, consequential and contingent damages or any kind or nature, including, without limitation: damages to persons or property, whether a claim for such damages is based upon warranty, contract, tort or otherwise; damages due to or arising out of the loss of time; or loss of profits.

dynoKRAFT GmbH shall not be responsible for any damages caused by the presence of error or omission in any of its manuals, instructions or related materials.

Conventions used in this manual

The conventions used in this manual are designed to protect both user and equipment and to assure a safe work environment.

⚠ Warning!

The warning indicates an lethal or other very serious safety hazard, or risk of equipment damage.

⚠ Caution

Caution means that failure to perform or incorrectly perform the described procedure can damage the equipment.

i Information

Information gives the technician additional useful advice.

Precautions and dynamometer safety

⚠ Engines exhaust gasses. Carbon monoxide. Toxic gasses.

Always assure proper dyno room ventilation and use engine exhaust extraction system which is adequately scaled to remove all exhaust gasses from the room in which people are working in.

Fail to do so may result in serious hazard to dyno room operators and will impact engine's performance.

Combustion engine exhaust gasses contain toxic carbon monoxide. Breathing it can cause death.

Always operate the dynamometer in well ventilated area. Always use exhaust gasses extraction system during test runs.

⚠ Noise and debris

Keep in mind that performing an engine test at high RPM and Load will create a noisy work environment which may affect one's ability concentrate on task he's performing.

Prolonged exposure to noise may result in head ache or nausea.

Always use eye protection to avoid eye damage from any debris or dirt which may be found in the air either because of extensive room ventilation or due to equipment damage.

⚠ Excessive noise. Eye damage.

Always use eye and ear protection while working with or servicing an dynamometer. Fail to do so may result in serious health issues, hearing loss or visual impairment .

⚠ Rotating parts

All rotating parts are potential source of serious accident. Therefore always operate the dynamometer with all coverings properly installed. Use additional covering or protection to secure any moving parts of the engine or dynamometer. Always ware tight sleeves to avoid getting dragged by any rotating parts.

Do not perform any repairs or servicing on a moving dynamometer.

⚠ Heat and Hot Surfaces

During an dynamometer test an substantial amount of heat will be generated by both the engine and dynamometer itself. The air temperature in the dyno room will rise gradually.

Additionally some surfaces of the dynamometer, the combustion or electric engine may get very hot.

dynoKRAFT is encouraging dynamometer operators to use an infrared thermometer to check if the surface temperatures are in safe range. Temperature above 55°C is considered harmful.

⚠ Electric power. Compressed air

The dynoKRAFT dynamometers are operated using electric power and compressed air.

Do not remove any covers, perform any service or repairs or open any electric cabinets while under power.

Any repairs or service which requires accessing the dynamometers electrical system may be performed only by qualified electrician.

Before performing any service operation or repairs to pneumatic components always release the pressure from the pneumatic system.

Please follow service procedures described below on details how to release the pressure.

⚠ Lethal voltage

Never perform any service, remove covers or open electric cabinets without previously disconnecting the main AC power.

Always wait minimum 5 minutes after turning off the dynamometer mains to allow for complete discharge of electromagnetic coils of the Eddy Current Brake(s).

Fail to do so may result in lethal electric shock.

General Information and Maintenance Schedule

General advice

⚠ Before performing any servicing of dynoKRAFT dynamometers please make sure to turn off the power, unplug the mains cord from wall socket and detach compressed air hose.
Fail to do so may result in serious injury or death!

⚠ When undoing any self-securing nut with plastic insert you must replace them with new nuts.
Fail to do so may result in loose bolt connections just after few test-runs!

⚠ When undoing any bolt secured by thread-lock please re-apply MEDIUM thread lock and tighten the bolt to specification - see chart below.
Fail to do so may result in loose bolt connections just after few test-runs!

Bolt Torque Chart per DIN 267

Standard thread pitch - values in Nm (Newtonmeter)

All bolts are to be tightened to values in table below, unless otherwise specified in this manual.

Size / Grade	4.6 / Alu	5.6	8.8	10.9	12.9
--------------	-----------	-----	-----	------	------

M4	1,0	1,3	3,0	4,3	5,1
M5	1,9	2,6	6,0	8,5	10,2
M6	3,4	4,5	10,3	14,7	17,6
M8	8,2	10,8	25,5	35,3	42,2
M10	16,7	21,6	50,0	70,6	85,3
M12	28,4	38,2	87,3	122,6	147,1
M14	45,1	60,8	138,3	194,2	235,4
M16	69,6	93,2	210,8	299,1	357,9
M20	135,3	180,45	411,9	578,6	696,3

Maintenance schedule

All dynoKRAFT dynamometers are to be services per following schedule.:

S - standard service operation

O - optional service operation

Maintenance scope / Schedule	Daily	Monthly	Yearly
Visual Inspection: - check for loose bolts or fixings - check for any visible damage - check for any damage of vehicle tie-down straps / chains / hook-in points - wipe-off any fluids - clean-up any dirt	S		
Electrical System: - check Emergency Stop system - check low air pressure indicator - check electric wheelbase adjustment function	S		
Pneumatic System: - check for leaks - drain water from air-bottle		S	
Main Bearings and bolts: - grease the main bearings - check if main bolts are tight		S	
Link System: - clean and re-lubricate the link shaft with anti-seize grease - check all cardan-join bolts		S	
Link System (A200- and A380- Series only): - check oil level in both bevel gearboxes		S	
Link System (A200- and A380- Series only): - replace oil in both bevel gearboxes *			O
* Replace oil once per year or every 2000 hours - whatever comes first			

Service Procedure

Before performing service job please read carefully all Warnings then remove all covers from dynamometer Main Frame(s).

Not all shown steps are applicable to all dynamometer models.

- ❗ You can check the current machine hours of your dynamometer in the ADAQexiom Plugin - see corresponding manual in this wiki.

1. Mechanical System

1.1 Check for loose components or visible damage.

Clean all dynamometer surfaces and the floor below the dynamometer to assure safe working Environment. Perform visual inspection of the whole dynamometer. Check for loose or damaged components or bolts.

- ❗ All important bolts and other components are marked with paint marker to allow easy visual inspection. If you need to replace or re-tighten them please re-apply the paint mark.

1.2 Re-grease all bearings

All Main Bearings and the Link Shaft central bearing must be re-greased.

Apply min. 20g of standard bearing grease per bearing, but not less than up to the point, where the fresh grease is protruding from the bearing housing.

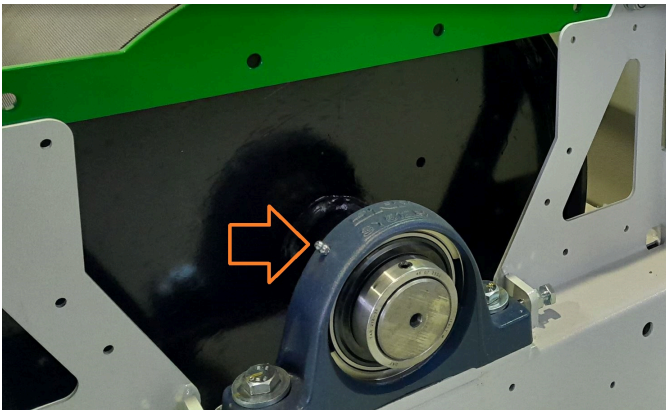

Apply fresh grease to Link Shaft bearing.

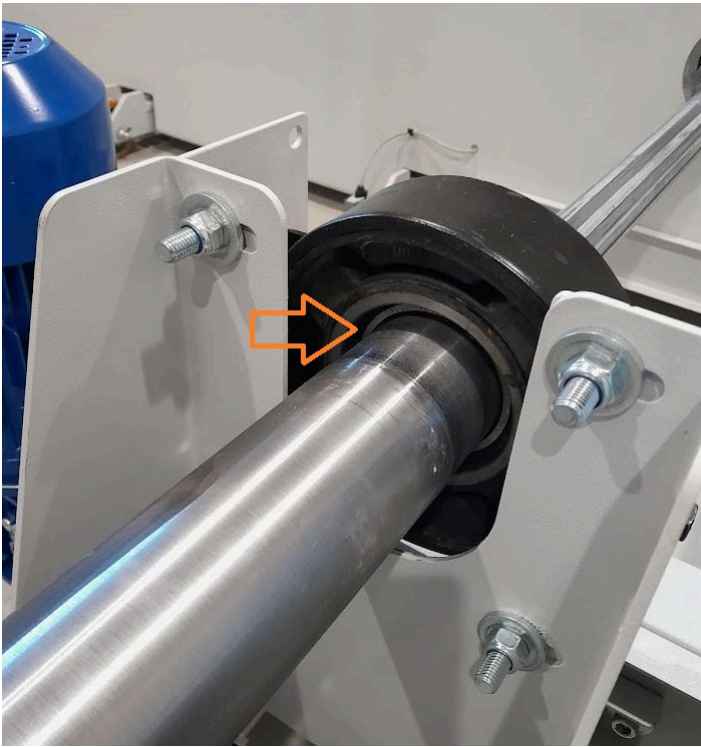

1.3 Check Main Bolts

Check all Main Bearing bolts of rotating assembly in each axle.
All bolts are marked with paint marker to ease the inspection.

- ⓘ Check-Torque is **125Nm**
If you find any loose bolt re-torque it to **135Nm**

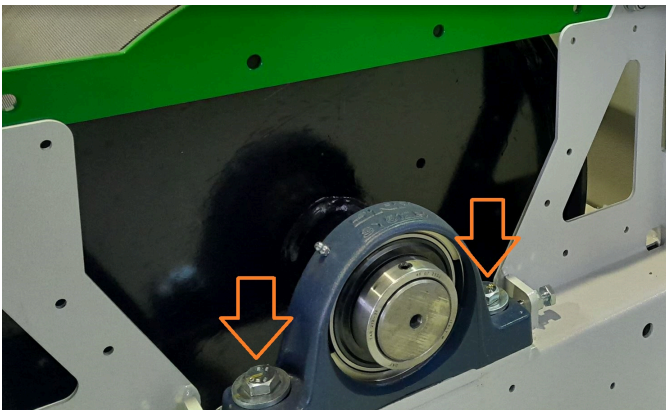

1.4 Check / Change oil in Link Gearbox

- ⓘ This step is applicable only for A380-4WD-ML and A200-4WD-ML models.
The A330-4WD-ML dynamometer Link Gearboxes are filled with Life-Time lubrication.

Check the oil level in Link Gearbox every month. Adjust as required.
Refer to A200- User Manual for detail on oil type.

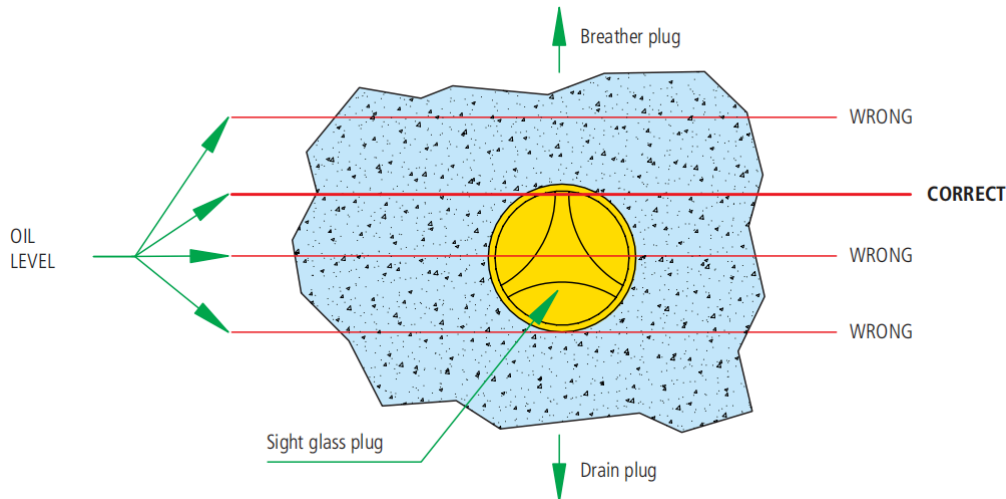

Replace the oil in Link Gearbox every 2000 machine hours.

1.5 Check and re-grease Link Shaft

i This step is applicable only to -4WD-ML dynamometers.

The Link Shaft must easily and without any excessive force move back and forth.

Extend the wheelbase to maximum setting then clean with degreaser the inner splined shaft.

Once the splined shaft is clean and wiped dry apply fresh thin layer of white anti-seize grease provided with dynamometer.



Check for excessive free-play of Link Shaft cardan joints.

Check markings / safety on all cardan joint bolts and re-torque them if needed.

⚠ Warning!

Should these bolts get loose during vehicle testing severe damage to dynamometer and/or test vehicle drive-train is possible!

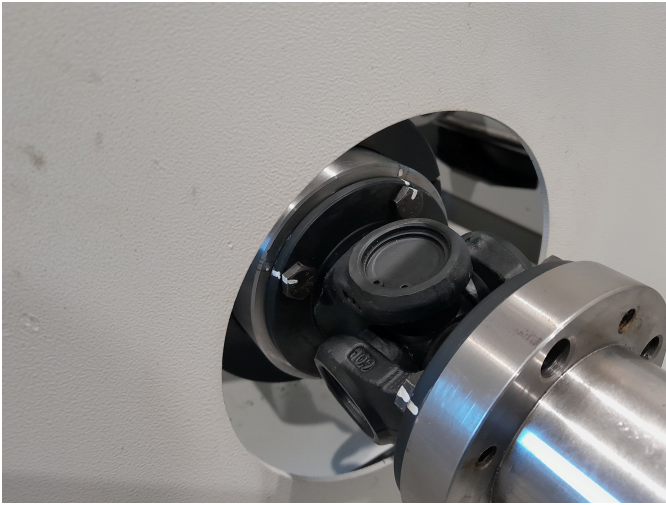

1.6 Check Spindle Drive system

Check the Spindle Drive system for loose parts. Pay special attention to shaft-nuts / axial free-play of the trapezoid screws.

If no excessive axial free-play can be observed and at least the visible shaft-nut is tight there is no need for adjustment.

All shaft-nuts are marked with paint-marker for easy inspection.

i One of the shaft-nuts is hidden inside the gearmotor housing.

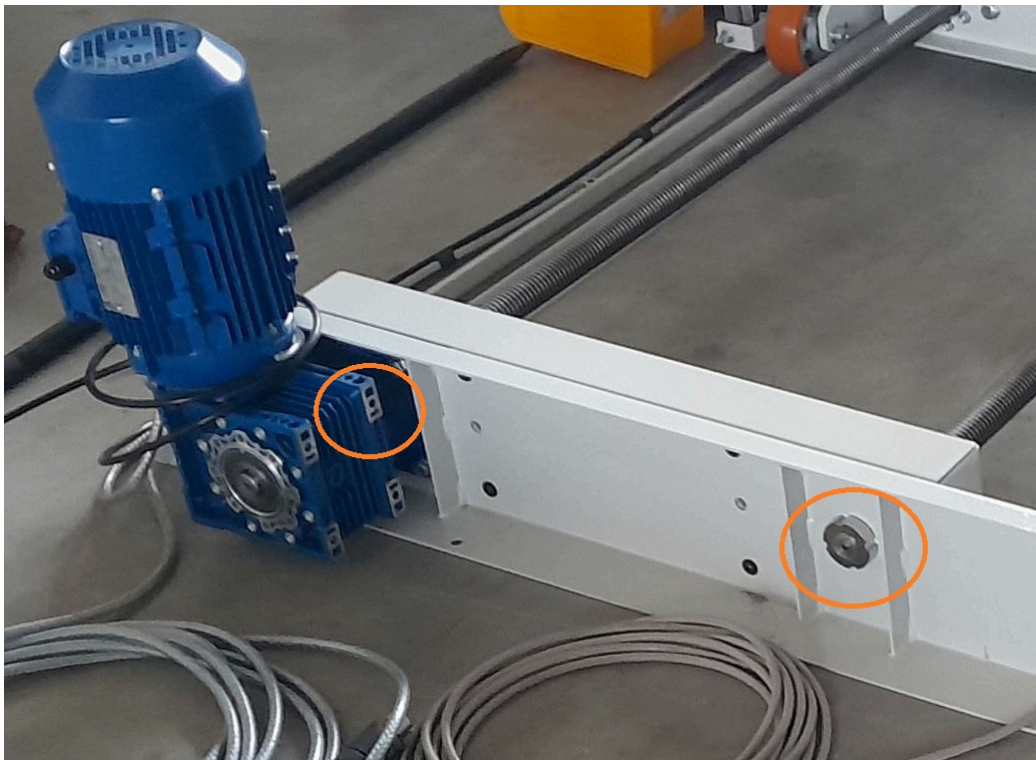

2. Electrical system

2.1 Function check

Verify the function of the following components:

1. Mains switch - check ON and OFF function.
2. E-stop button - depress then pull the E-stop button - the E-stop pneumatic brakes should engage.
3. Reset button - press the Reset button - the E-stop pneumatic brakes should disengage.
4. Perform visual inspection of all cables and connectors. Look for damage or loose components.

3. Pneumatic system

3.1 Air pressure

Verify that the air pressure supply is set to 7-8 bar.

Release the E-stop button and Reset the dynamometer to normal operation mode.

3.2 Pneumatic E-stop brake(s)

With dynamometer reset to normal operation mode (rollers can rotate freely) verify and re-adjust the brake pads gap for each pneumatic brake caliper.

The max. allowed gap (free play) is 0,5mm

⚠ Before adjusting the free play make sure that the system pressure is set to 7-8 bar!

The free-play can be adjusted by rotating the M16 bolt found on the brake caliper.

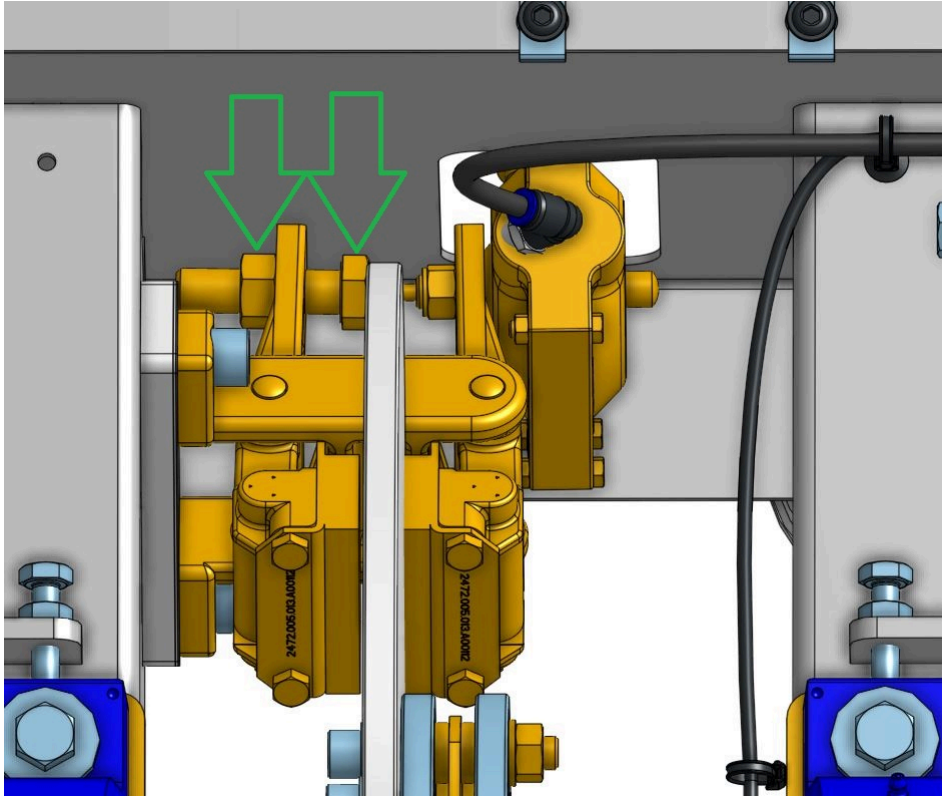

3.3 "Air" indicator function check

Close the air supply to dynamometer and release the pressure from the system.

You can release the air pressure by either levering the safety valve (or pulling the ring found on safety valve).

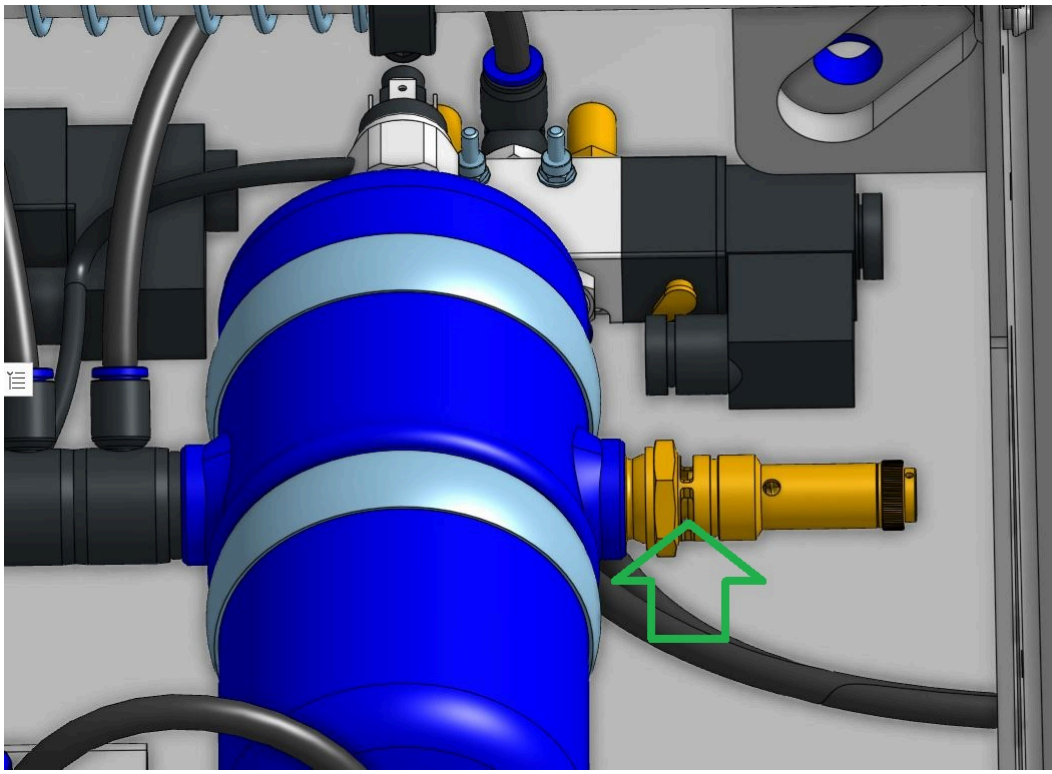

With air released from the system the red "Air" LED in control panel should light-up upon pressing the "Reset" button.

3.4 Drain water from air bottle

With air pressure released from the dynamometer drain water from the blue air bottle by detaching the black air-hose from bottom fitting.

You can detach the hose by pressing the blue locking ring on the air fitting while gently pulling on the hose itself.

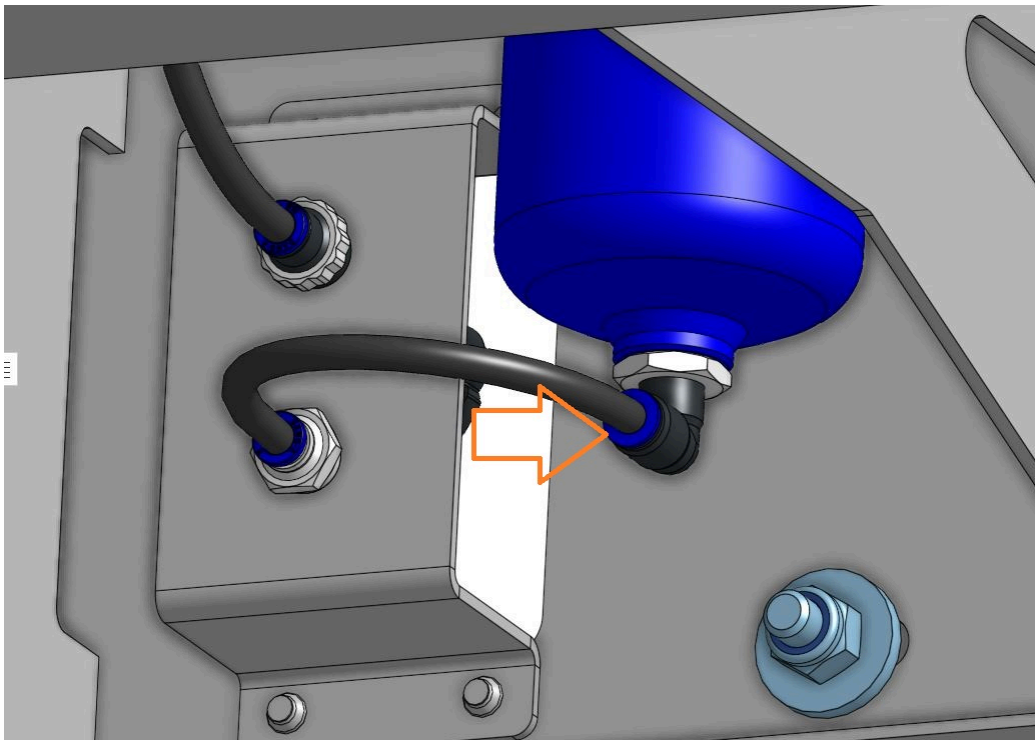

After the water is drained re-attach the hose by pushing it back into the fitting up to the point where you can feel it locks into place.

4. Software and ADAQ check

Perform standard Load Cell calibration.

Verify the Hall-Sensor operation by checking the RPM1 / RPM2 inputs in software.

Check the Retarder Power Supply operation either directly in Software Options or by manually operating the Brake % in Test-Window.

📌 Update to latest ADAQ / YourDyno software if desired.

Final Notes

After all service procedures are complete re-install all removed covers and/or parts.

Perform standard Power Sweep test to verify the dynamometer operation.

⚠ Please fill-out the attached Service Protocol (see PDF file at the bottom of this page) and send it per email to: info@dynoKRAFT.de to maintain your warranty.